

FOR OFFICIAL USE

--	--	--	--	--	--

C

KU PS

Total  
Marks

--	--

**0500/31/01**

NATIONAL  
QUALIFICATIONS  
2013

WEDNESDAY, 1 MAY  
10.50 AM – 12.20 PM

CHEMISTRY  
STANDARD GRADE  
Credit Level

Fill in these boxes and read what is printed below.

Full name of centre

Town

Forename(s)

Surname

Date of birth

Day Month Year

--	--	--	--	--	--

Scottish candidate number

--	--	--	--	--	--	--	--	--	--

Number of seat

- 1 All questions should be attempted.
- 2 Necessary data will be found in the Data Booklet provided for Chemistry at Standard Grade and Intermediate 2.
- 3 The questions may be answered in any order but all answers are to be written in this answer book, and must be written clearly and legibly in ink.
- 4 Rough work, if any should be necessary, as well as the fair copy, is to be written in this book.  
Rough work should be scored through when the fair copy has been written.
- 5 Additional space for answers and rough work will be found at the end of the book.
- 6 The size of the space provided for an answer should not be taken as an indication of how much to write. It is not necessary to use all the space.
- 7 Before leaving the examination room you must give this book to the Invigilator. If you do not, you may lose all the marks for this paper.



## PART 1

In Questions 1 to 8 of this part of the paper, an answer is given by circling the appropriate letter (or letters) in the answer grid provided.

In some questions, two letters are required for full marks.

If more than the correct number of answers is given, marks will be deducted.

A total of 20 marks is available in this part of the paper.

### SAMPLE QUESTION

A	CH <sub>4</sub>	B	H <sub>2</sub>	C	CO <sub>2</sub>
D	CO	E	C <sub>2</sub> H <sub>5</sub> OH	F	C

(a) Identify the hydrocarbon.

Ⓐ	B	C
D	E	F

The one correct answer to part (a) is A. This should be circled.

(b) Identify the **two** elements.

A	Ⓑ	C
D	E	Ⓕ

As indicated in this question, there are **two** correct answers to part (b). These are B and F.

Both answers are circled.

If, after you have recorded your answer, you decide that you have made an error and wish to make a change, you should cancel the original answer and circle the answer you now consider to be correct. Thus, in part (a), if you want to change an answer A to an answer D, your answer sheet would look like this:

<del>Ⓐ</del>	B	C
Ⓓ	E	F

If you want to change back to an answer which has already been scored out, you should enter a tick (✓) in the box of the answer of your choice, thus:

✓ <del>Ⓐ</del>	B	C
<del>Ⓓ</del>	E	F

Marks

1. The grid shows the names of some elements.

A hydrogen	B copper	C oxygen
D iron	E magnesium	F iodine

(a) Identify the element which melts at 1083 °C.

You may wish to use the data booklet to help you.

A	B	C
D	E	F

1

(b) Identify the element produced in a blast furnace.

A	B	C
D	E	F

1

(c) Identify the element which burns with a pop.

A	B	C
D	E	F

1

(3)

[Turn over

Marks

	KU	PS
1		
1		
1		
(3)		

2. The grid shows some ions.

A	$\text{Al}^{3+}$	B	$\text{Cl}^-$	C	$\text{Li}^+$
D	$\text{H}^+$	E	$\text{Br}^-$	F	$\text{OH}^-$

(a) Identify the ion with the same electron arrangement as a helium atom.

You may wish to use the data booklet to help you.

A	B	C
D	E	F

1

(b) Identify the **two** ions which combine to form an insoluble compound.

You may wish to use the data booklet to help you.

A	B	C
D	E	F

1

(c) Identify the ion present in all alkaline solutions.

A	B	C
D	E	F

1

(3)

Marks

KU	PS
----	----

3. Electricity can be produced using electrochemical cells.

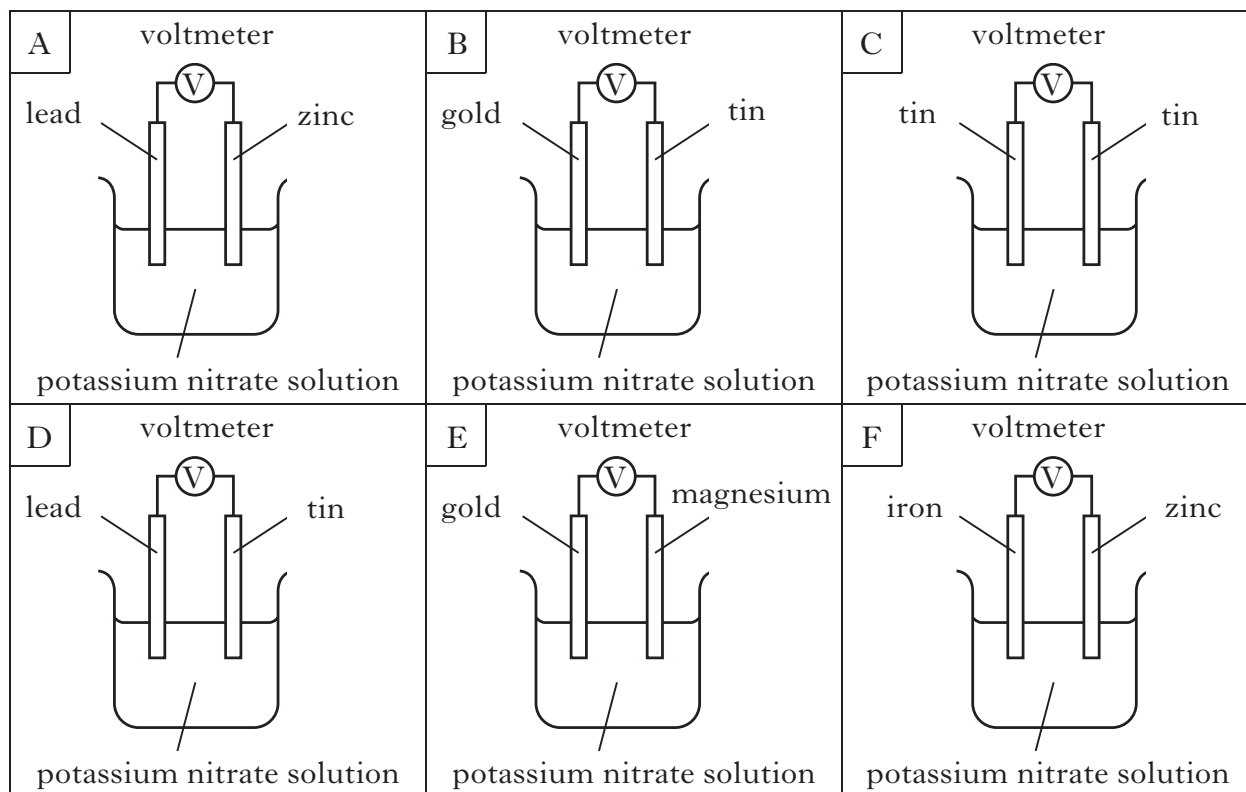

(a) Identify the arrangement which would **not** produce electricity.

A	B	C
D	E	F

1

(b) Identify the **two** cells which could be used to compare the reactivity of gold and lead.

A	B	C
D	E	F

1  
(2)

[Turn over

Marks

	KU	PS
1		
1		
1		
(3)		

4. The grid shows the names of some carbohydrates.

A	fructose
B	glucose
C	maltose
D	starch
E	sucrose

(a) Identify the condensation polymer.

A
B
C
D
E

(b) Identify the **two** disaccharides.

A
B
C
D
E

(c) Identify the **two** carbohydrates which **cannot** be hydrolysed.

A
B
C
D
E

Marks

5. A student made some statements about the effect of adding water to an acidic solution.

A	The pH of the solution will stay the same.
B	The acidity of the solution will decrease.
C	The pH of the solution will fall.
D	The acidity of the solution will increase.
E	The solution will become less concentrated.

Identify the **two** correct statements.

A
B
C
D
E

(1)

[Turn over

KU	PS

Marks

KU	PS
----	----

6. The grid shows the structural formulae of some monomers.

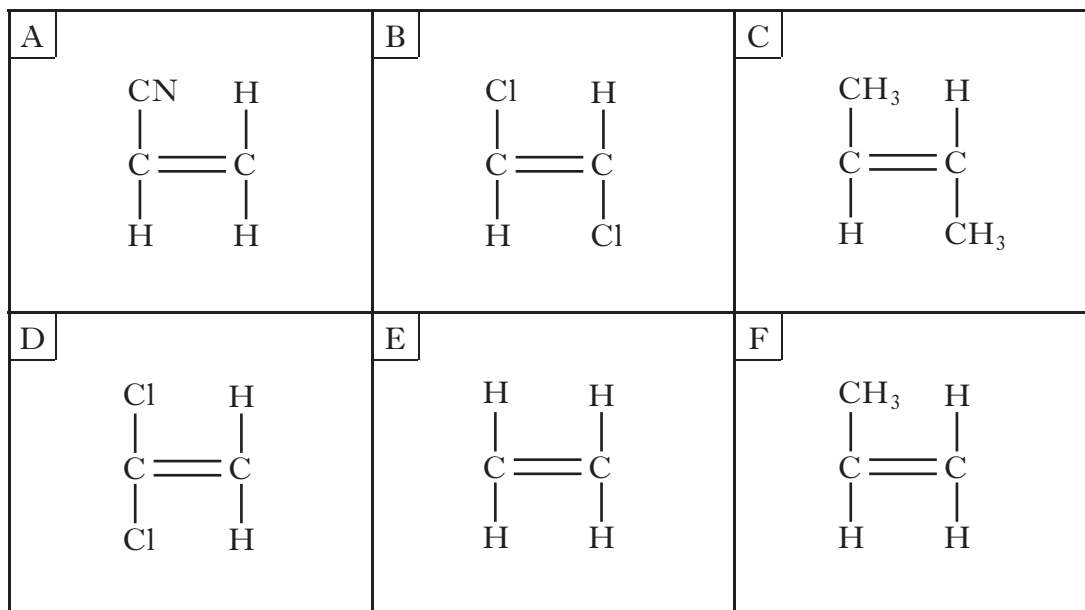

(a) Identify the monomer which would form poly(propene).

A	B	C
D	E	F

1

(b) Identify the monomer which reacts with hydrogen to form ethane.

A	B	C
D	E	F

1

(c) Identify the **two** isomers.

A	B	C
D	E	F

1





Marks

KU	PS

## 6. (continued)

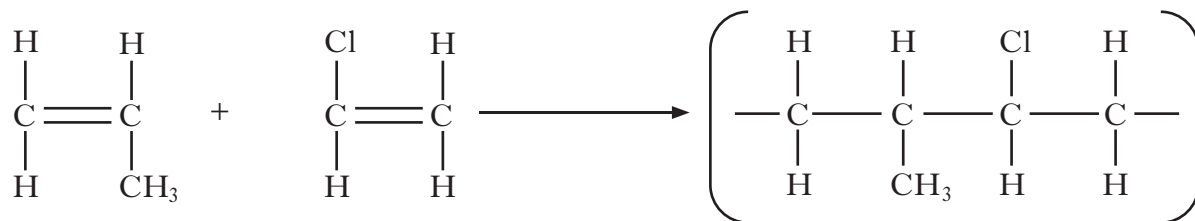
(d) When two **different** monomers polymerise a copolymer is formed as shown.



Identify the **two** monomers which would polymerise to give the copolymer below.

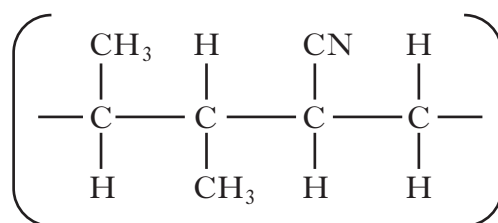

A	B	C
D	E	F

1  
(4)

[Turn over]



Marks

8. Several conductivity experiments were carried out using the apparatus below.

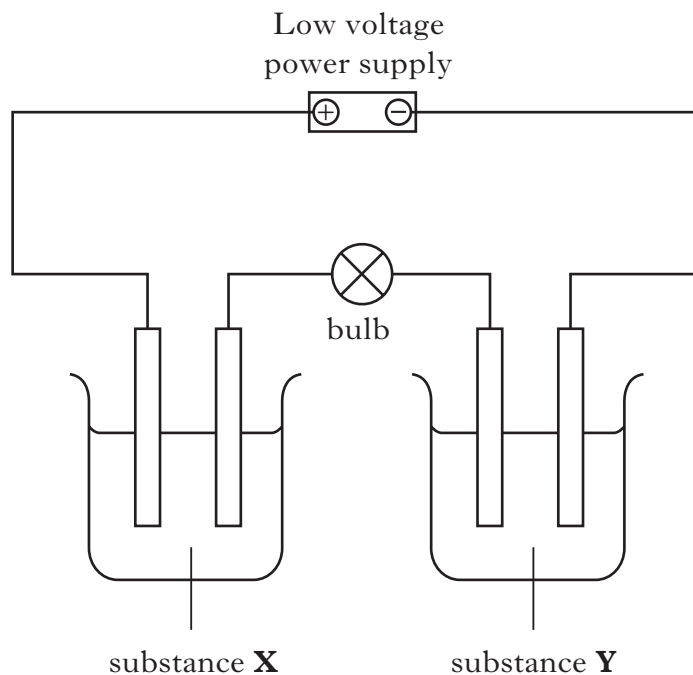

Experiment	Substance X	Substance Y
A	glucose solution	sodium chloride solution
B	copper nitrate solution	solid potassium nitrate
C	molten tin	liquid mercury
D	potassium sulphate solution	liquid hexane
E	lithium chloride solution	molten nickel bromide

Identify the **two** experiments in which the bulb would light.

A
B
C
D
E

(2)

**[Turn over for Part 2 on Page twelve**



Marks

	KU	PS
1		
1		
1		
(3)		

10. The nuclide notation for an isotope of hydrogen is  ${}^1_1\text{H}$ .

(a) An isotope of copper has atomic number 29 and mass number 63.

(i) Write the nuclide notation for this isotope of copper.

(ii) How many neutrons are present in this isotope of copper?

\_\_\_\_\_

(b) A sample of copper was found to contain **equal** amounts of two isotopes. One has mass number 63 and the other has mass number 65.

What is the relative atomic mass of this sample of copper?

\_\_\_\_\_

[Turn over

Marks

KU	PS

11. The table shows information about some useful compounds.

Compound	Formula
<b>Y</b>	$\text{Na}_3\text{PO}_4$
ammonia	$\text{NH}_3$
ammonium nitrate	$\text{NH}_4\text{NO}_3$

(a) (i) Name compound **Y**.

\_\_\_\_\_

1

(ii) Compound **Y** can be used as a fertiliser.

Why are fertilisers added to soil?

\_\_\_\_\_

\_\_\_\_\_

\_\_\_\_\_

1

(b) Name the catalyst used in the industrial manufacture of ammonia.

\_\_\_\_\_

1

(c) What is present in the root nodules of some plants which convert nitrogen from the atmosphere into nitrogen compounds?

\_\_\_\_\_

1

(4)

Marks	KU	PS
1		
1		
1		
1		
(4)		

12. Crude oil can be separated into fractions.

- (a) One of the fractions contains alkane molecules with chain lengths from five to eight carbons.

Using information in the data booklet, state the boiling point **range** for this fraction.

\_\_\_\_\_ °C to \_\_\_\_\_ °C

- (b) The table gives information about some alkanes.

Name	Density g/cm <sup>3</sup>
pentane	0.626
hexane	0.659
heptane	0.684
octane	0.703

Predict the density of the alkane with **nine** carbon atoms.

\_\_\_\_\_ g/cm<sup>3</sup>

- (c) A student investigated the reaction of some fuels with oxygen. The results are shown.

Fuel	Products
A	carbon dioxide
B	water
C	nitrogen, water
D	carbon dioxide, water

- (i) Name the **elements** which **must** be present in fuel **D**.

\_\_\_\_\_

- (ii) Suggest a name for fuel **B**.

\_\_\_\_\_

Marks

13. Dilute hydrochloric acid reacts with sodium thiosulphate,  $\text{Na}_2\text{S}_2\text{O}_3$ , as shown in the equation below.



- (a) Suggest a name for the **type** of chemical reaction taking place.

---

1

- (b) A student investigated the effect of temperature on the rate of the reaction.

The student measured the time taken for enough sulphur to form to make the cross disappear.

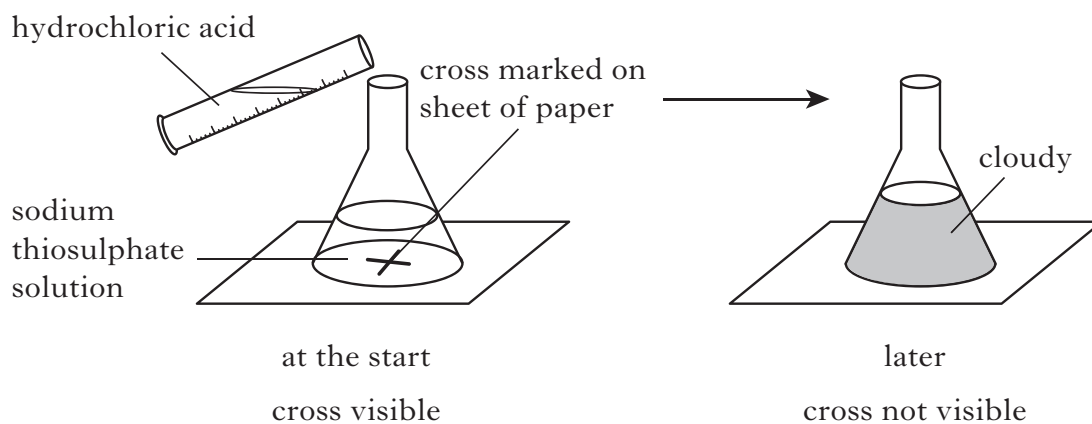

The results are shown.

Temperature/ $^{\circ}\text{C}$	Time/s
25	89
30	64
35	44
40	33
45	27

Write a general statement describing the effect of temperature on the **rate** of the reaction.

---



---

1

(2)



Marks	Marks	
	KU	PS
1		
1		
1		
1		
1		
1		
(4)		

14. Zinc displaces copper from copper(II) sulphate solution.

The equation for the reaction is:

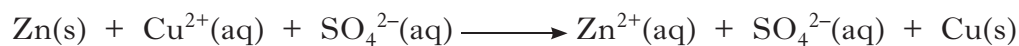

- (a) **Circle** the spectator ion in the above equation.
- (b) Write the ion-electron equation for the **oxidation** step in this reaction.  
You may wish to use the data booklet to help you.

(c) The reaction can also be carried out in a cell.

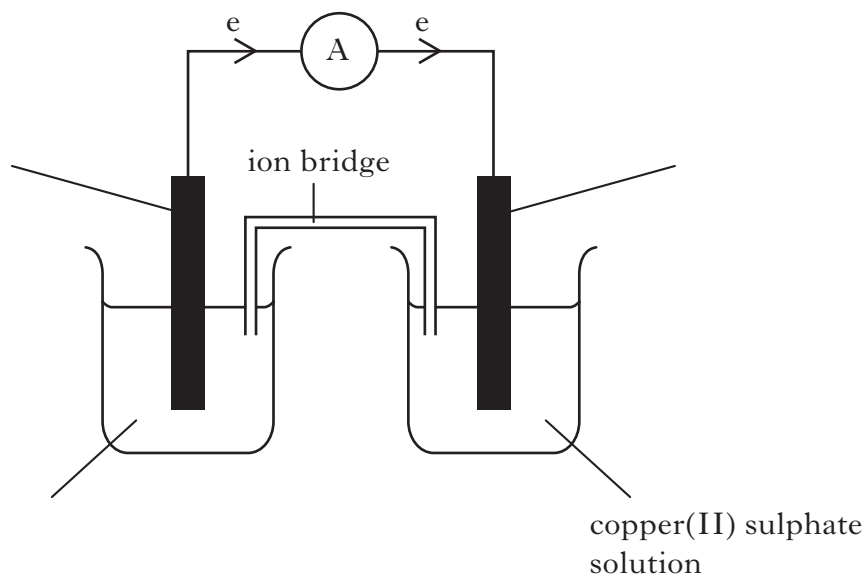

- (i) Complete the **three labels** on the diagram.  
(An additional diagram, if required, can be found on page 24.)
- (ii) What is the purpose of the ion bridge?

---



---

[Turn over

Marks

KU	PS
1	
1	
1	

15. An antibacterial hand gel contains two alkanols, ethanol and propan-2-ol.

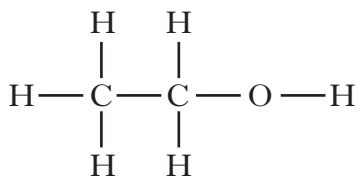

ethanol

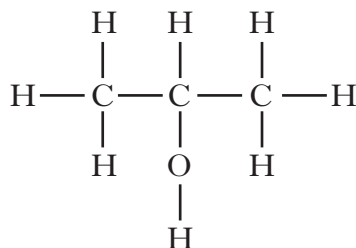

propan-2-ol

- (a) Alkanols are a homologous series containing carbon, hydrogen and oxygen.

Suggest a general formula for alkanols.

- (b) Ethanol can be produced by the fermentation of glucose.

- (i) Name the gas produced during the fermentation of glucose.

\_\_\_\_\_

- (ii) Name the process used to increase the ethanol concentration of fermentation products.

\_\_\_\_\_

Marks

KU	PS
----	----

## 15. (continued)

(c) When alkanols are oxidised alkanolic acids are produced.

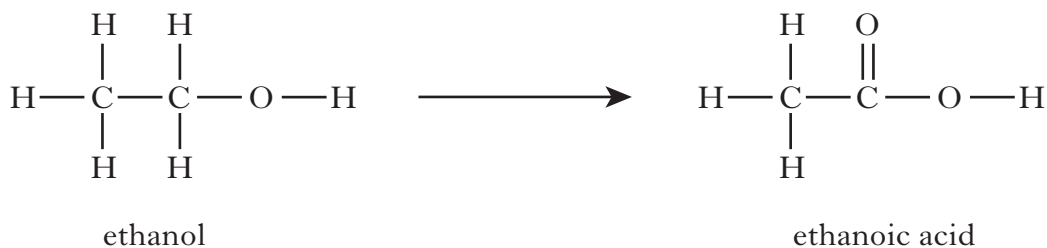
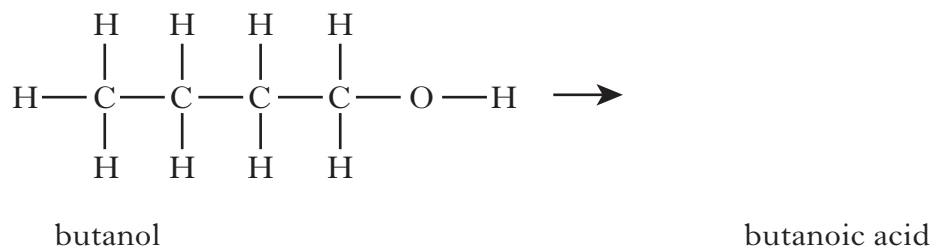
Draw the **full** structural formula for the alkanolic acid produced when butanol is oxidised.

1

(d) Esters are produced when alkanols react with alkanolic acids.

The table gives information on esters.

Alkanol	Alkanolic acid	Ester
methanol	ethanoic acid	methyl ethanoate
ethanol	propanoic acid	ethyl propanoate
propanol	methanoic acid	propyl methanoate
butanol	ethanoic acid	butyl ethanoate
pentanol	butanoic acid	<b>X</b>

Suggest a name for **X**.

\_\_\_\_\_

1  
(5)

[Turn over

Marks

KU	PS

16. Metals can be extracted from their ores by different methods.

(a) Place the following methods in the correct space in the table.

You may wish to use the data booklet to help you.

- reacting with carbon**
- electrolysis**
- heat alone**

Metal	Method
mercury	
iron	
magnesium	

1

(b) Mercury can be extracted from the ore cinnabar, **HgS**.

(i) Calculate the percentage by mass of mercury in cinnabar.

\_\_\_\_\_ % 2

(ii) Write the formula for the mercury ion in cinnabar.

\_\_\_\_\_

1

(4)

Marks

	KU	PS
17. Nitrogen trifluoride, NF <sub>3</sub> , is used in the manufacture of plasma screens.		
(a) Draw a diagram showing <b>all</b> outer electrons to represent a molecule of nitrogen trifluoride.		
(b) The atoms in nitrogen trifluoride are held together by covalent bonds. Circle the correct words to complete the sentence. A covalent bond forms when two $\left\{ \begin{array}{l} \text{positive} \\ \text{negative} \\ \text{neutral} \end{array} \right\}$ nuclei are held together by their common attraction for a shared pair of $\left\{ \begin{array}{l} \text{protons} \\ \text{neutrons} \\ \text{electrons} \end{array} \right\}$ .		
(c) The equation for the formation of nitrogen trifluoride, NF <sub>3</sub> , is: $\text{N}_2 + 3\text{F}_2 \longrightarrow 2\text{NF}_3$ Calculate the mass of nitrogen trifluoride produced from 7 g of nitrogen. <b>Show your working clearly.</b>  _____ g		

17. Nitrogen trifluoride, NF<sub>3</sub>, is used in the manufacture of plasma screens.

(a) Draw a diagram showing **all** outer electrons to represent a molecule of nitrogen trifluoride.

(b) The atoms in nitrogen trifluoride are held together by covalent bonds.

Circle the correct words to complete the sentence.

A covalent bond forms when two  $\left\{ \begin{array}{l} \text{positive} \\ \text{negative} \\ \text{neutral} \end{array} \right\}$  nuclei are held together  
by their common attraction for a shared pair of  $\left\{ \begin{array}{l} \text{protons} \\ \text{neutrons} \\ \text{electrons} \end{array} \right\}$ .

(c) The equation for the formation of nitrogen trifluoride, NF<sub>3</sub>, is:

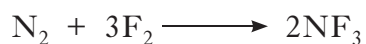

Calculate the mass of nitrogen trifluoride produced from 7 g of nitrogen.

**Show your working clearly.**

\_\_\_\_\_ g

**[Turn over for Question 18 on Page twenty-two**

Marks

KU	PS
2	
1	

18. A student investigated the reaction between dilute sulphuric acid and sodium carbonate.

(a) One experiment involved measuring the volume of carbon dioxide produced when solid sodium carbonate was used.

<b>Time/s</b>	0	10	30	40	50	60	70
<b>Volume of carbon dioxide/cm<sup>3</sup></b>	0	12	29	34	36	37	37

(i) Draw a line graph of these results.

*Use appropriate scales to fill most of the graph paper.*

(Additional graph paper, if required, will be found on page 24.)

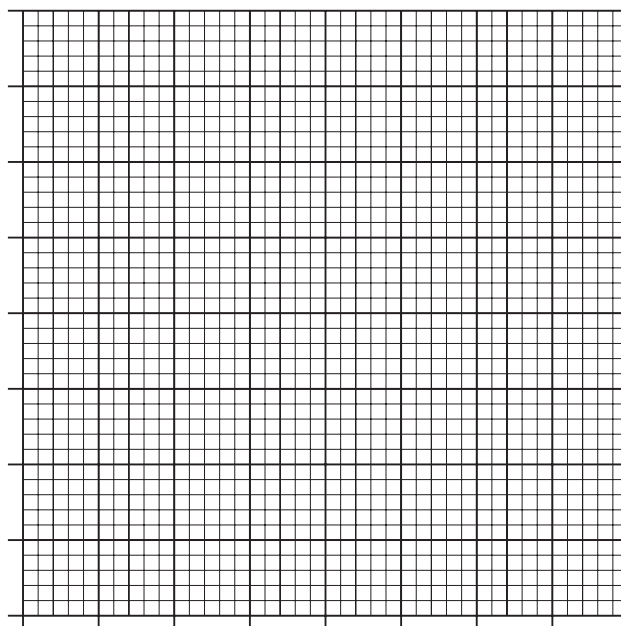

2

(ii) The experiment was repeated at a higher temperature.

The volume and concentration of sulphuric acid and the mass of sodium carbonate were kept the same.

Predict the final volume of carbon dioxide produced at this temperature.

\_\_\_\_\_ cm<sup>3</sup>

1

Marks

## 18. (continued)

- (b) Another experiment involved determining the concentration of sodium carbonate solution by titration.

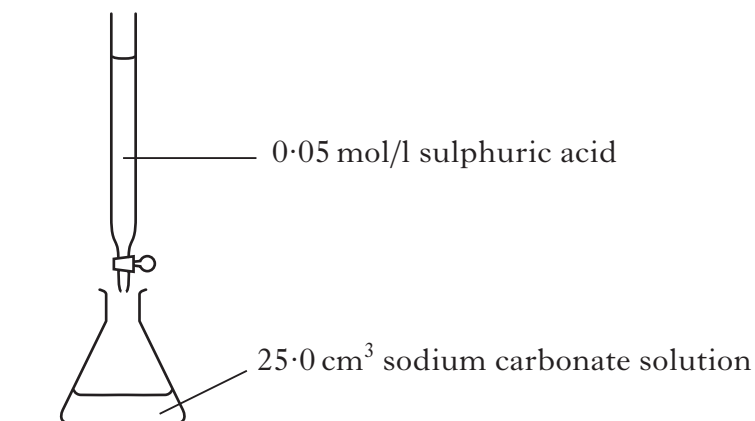

The results showed that 20 cm<sup>3</sup> of sulphuric acid was required to neutralise the sodium carbonate solution.

- (i) Calculate the number of moles of sulphuric acid in this volume.

\_\_\_\_\_ mol

1

- (ii) One mole of sulphuric acid reacts with one mole of sodium carbonate.

Using your answer from part (b)(i), calculate the concentration, in mol/l, of the sodium carbonate solution.

\_\_\_\_\_ mol/l

1

- (c) Name the salt produced when dilute sulphuric acid reacts with sodium carbonate.

\_\_\_\_\_

1

(6)

[END OF QUESTION PAPER]

**ADDITIONAL SPACE FOR ANSWERS**

ADDITIONAL DIAGRAM FOR QUESTION 14(c)

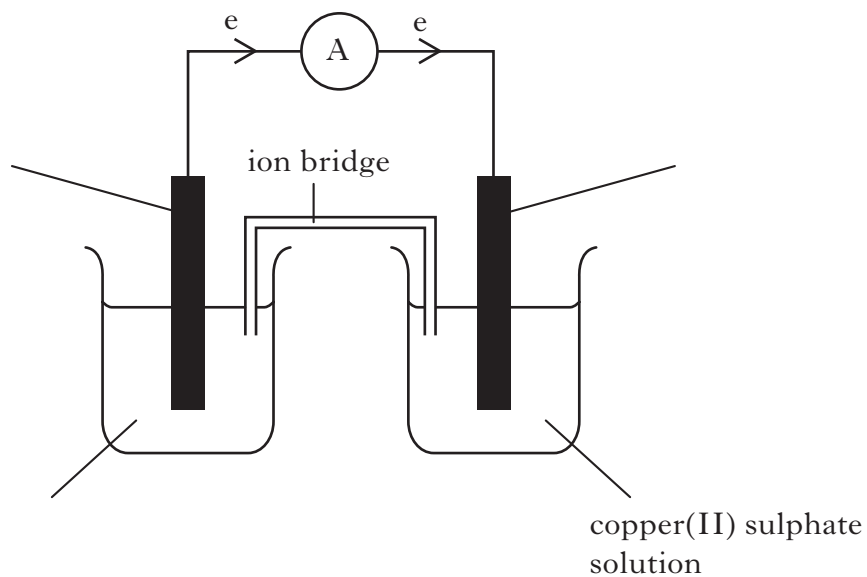

ADDITIONAL GRAPH PAPER FOR QUESTION 18(a)(i)

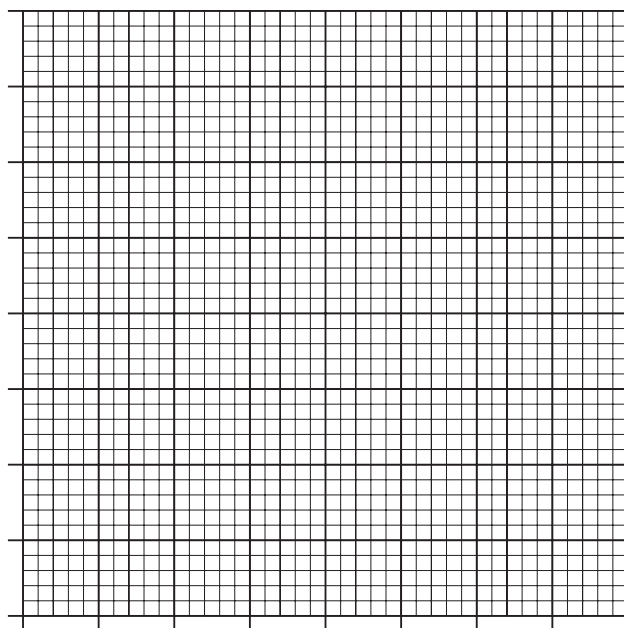



**ADDITIONAL SPACE FOR ANSWERS**

KU	PS

**ADDITIONAL SPACE FOR ANSWERS**

KU	PS

**[BLANK PAGE]**

**[BLANK PAGE]**